

Heat Recovery Ventilation Unit

ECO FRESH 07

Save Energy

GOLDEN MEDAL

IFP

Internacional
Technical
Fair
Plovdiv



PROVIDING A CLEAN & HEALTHY ENVIRONMENT FOR ASTHMA AND ALLERGY SUFFERERS



Clean air is an essential factor our health. Modern man does not even know how many of his health problems are caused by air in his own home or workplace.

It has been shown that the air quality in our well sealed and well-insulated homes and workplaces is not healthy, and this is where we spend 90% of our lives.

The heat recovery unit "Eco-Fresh" is designed for local ventilation of residential and commercial premises.

Creates healthy indoor climate by supplying fresh air. Passing through the system of filters the air is purified from dust, soot, bacteria, etc.

When needed in the cold winter days the incoming air is heated to room temperature.

Hydrostatic system controls humidity, keeping it in the range below 75%, which limits the humidification and aging of the premises, and prevents the formation of mold and mildew.

The built-in ionizer fills the air with negative ions, which has antiseptic effect, kills disease-causing microorganisms - viruses and bacteria, preventing infections and acute respiratory diseases.

Ionized air improves working capacity, eliminates the fatigue, and positively affects the overall health conditions

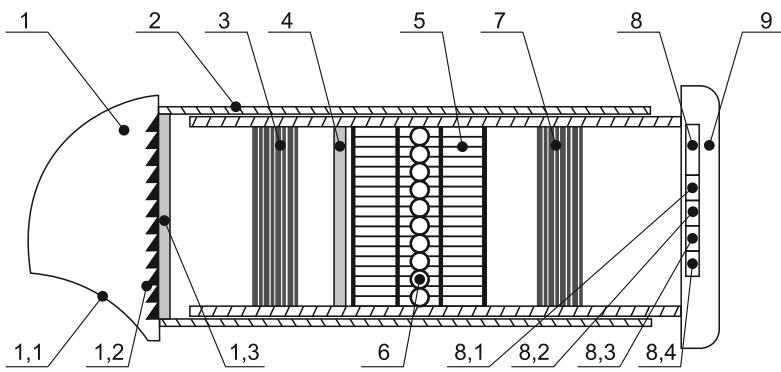

The airflow system "Eco-Fresh 07" is composed of:

- Outer protective grille – protects the system from humidity even during heavy rains. Consists of a housing (1.1); grate (1.2); grid (1.3).
- Extensible air funnel – allows regulation of the system length, depending on wall thickness.
- Exhaust fan – five-speed, allows regulation of fan duty from 30m³/h in night silent mode, up to 120m³/h in day mode.
- Filter with charcoal – guarantees the clean airflow even in strong polluted urban areas and industrial regions. Cleans the air from smells, dust, bacteria, soot, car exhaust gases and other.
- Heatexchanger – contributes to a significant reduction of heat loss during ventilation.
- Heater 420W – economical, designed for pulse operation. Maintain the temperature of the incoming air 23°C.
- Blast fan – five-speed, allows regulation of fan duty from 30m³/h in night silent mode, up to 120m³/h in day mode. Serves for blasting clean air from outside.
- Control unit
 - Thermal fuse – protects the system from overheating.
 - Thermostat – manages the heater and ensures 23°C of incoming air.
 - Hydrostat - controls humidity, maintaining it in the range below 70%.
 - Ionizer – filling up the air with negative ions. Removes specific and unpleasant odors. Kills pathogenic microorganisms. Protects from fungus and mold.
- Decorative grille – does not take any space in the room, can be executed in different colors.

Remote control (fig.1):

Start/Stop – switches on/off the system.

AIR FLOW

- Mode (reversible ventilation with thermal energy recovery).

The system blasts clean air from outside to inside and disposes polluted air out of the room. A heat recovery is observed – process of recovering heat from outgoing warm but polluted air. The warm air which is going out through exchanger is rendering its heat to the incoming clean air. This contributes to a significant reduction of heat loss during winter days. In summer the opposite process is observed – the cool air from air-conditioning which is going out through exchanger is chilling the incoming clean but warm air. In the exchanger is achieved efficiency of heat regeneration that exceeds 90%.

AIR FLOW

- mode "Air Influx" – the system is constantly submitting clean air from outside to inside.

AIR FLOW

- mode "Air Exhaust" – by protracted press over 10 seconds the system is working as a fan.

SLEEP

In sleep mode and without light in the room the system turns off automatically after 10 minutes.

At lightening the system will be in working mode after 2 hours retaining the previous settings.

STANDBY

Heater, fan and ionizer are stopped. But the hydrostatic system monitors the humidity and when it exceeds 75% the fan and ionizer are automatically switched on. They stop working 10 minutes after the humidity level drops below 75%.

FAN SPEED – operate the fan speed. A selection between 5 speeds – first speed – 30m³/h in night silent mode, and last fifth speed – max. 120m³/h in day mode.

ON/OFF - switch on/off the hydrostatic system

ON/OFF - switches on/off the ionizer

ON/OFF - switches on/off the mode "heating of incoming air"

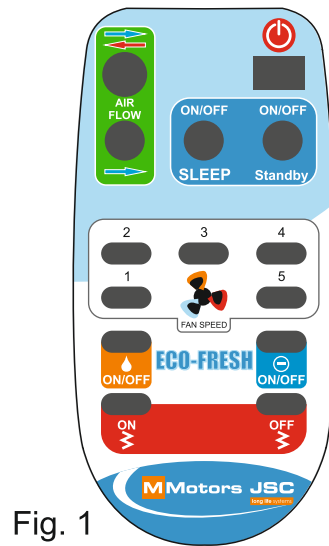
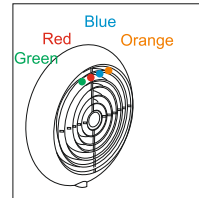

Fig. 1



LIGHT EMITTING DIODES

Green diode

* when is not lit the system does not work (or work as a fan) Air Flow

*when it is lit:

- the system is in mode Air Flow
- if flashes the system is in mode Air Flow

Red diode

* when is not lit the heater is off

* when it is lit:

- the system is in mode of heating the air, but the heater does not operate if the temperature of incoming air is over 23°C.
- if flashes the incoming air temperature is below 17°C.

Blue diode

* when is not lit the ionizer is off

* when it is lit the ionizer is on

Orange diode

* when is not lit the humidity sensor is off

* when it is lit:

- the system is in mode of controlling the humidity
- when flashes the humidity level exceeds 70%

Features

- In Standby mode are lit green, blue and orange diodes, and the system is not working if the humidity is below 70%. When the humidity exceeds that level the ionizer and fan start working automatically on speed 3. The sensor monitors the humidity and 10 minutes after it is reduced below 70% the ionizer and fan stop working;
- The heater can be optionally switched on (red diode is lit), which guarantees warm air inflow when the system is working due to high humidity.
- Desired combination of functions can be chosen from the remote control.

Technical data

Min. wall thickness 32cm.

Model	Rated Voltage Hz/V	Maximum Flow m ³ /h	Power Consumption		Maximum rotational speed min ⁻¹	Protection Degree IP
			fan	heater		
07	50/230	120	46	420	2650	X4

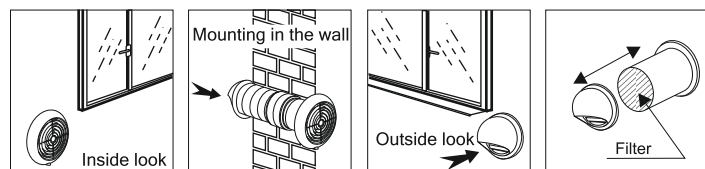
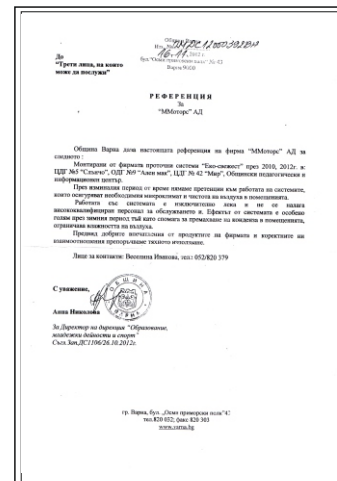
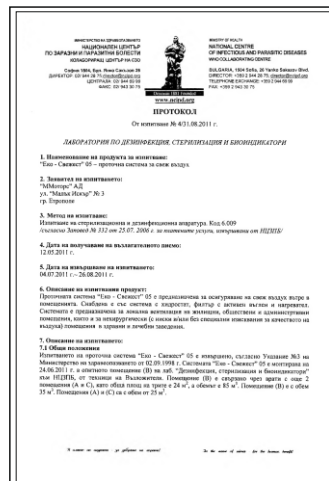

Fig. 2

Demonstrated by research of National Center of Infectious and Parasitic Diseases - WHO Collaborating Centre, "In the room in which the system is installed, the average reduction of normal air microflora is 80%. The system rapidly reduces the possibility of contamination with acute respiratory diseases, both in residential and commercial premises and in hospital rooms. /Reference of Hospital Saint Marina – Varna Bulgaria/